

# Installation Guide

## Agilent Technologies N5181A/82A MXG Signal Generators

This guide applies to the following signal generator models:

**N5181A MXG Analog Signal Generator**

**N5182A MXG Vector Signal Generator**

Due to our continuing efforts to improve our products through firmware and hardware revisions, signal generator design and operation may vary from descriptions in this guide. We recommend that you use the latest revision of this guide to ensure you have up-to-date product information. Compare the print date of this guide (see bottom of page) with the latest revision, which can be downloaded from the following website:

*<http://www.agilent.com/find/mxg>*



**Agilent Technologies**

**Manufacturing Part Number: N5180-90002**

**Printed in USA**

**September 2006**

© Copyright 2006 Agilent Technologies, Inc.

## Notice

The material contained in this document is provided “as is”, and is subject to being changed, without notice, in future editions.

Further, to the maximum extent permitted by applicable law, Agilent disclaims all warranties, either express or implied with regard to this manual and to any of the Agilent products to which it pertains, including but not limited to the implied warranties of merchantability and fitness for a particular purpose. Agilent shall not be liable for errors or for incidental or consequential damages in connection with the furnishing, use, or performance of this document or any of the Agilent products to which it pertains. Should Agilent have a written contract with the User and should any of the contract terms conflict with these terms, the contract terms shall control.

<b>1</b>	<b>Safety Information</b>	
	Warnings, Cautions, and Notes . . . . .	.1
	General Safety Considerations . . . . .	.1
	Instrument Markings . . . . .	.2
<b>2</b>	<b>Getting Started</b>	
	Checking the Shipment . . . . .	.3
	Signal Generator Physical Characteristics . . . . .	.3
	Meeting Environmental and Electrical Requirements . . . . .	.4
	Environment . . . . .	.4
	Ventilation . . . . .	.4
	Line Setting Requirements . . . . .	.4
	Connecting the AC Power Cord . . . . .	.5
	AC Power Cord Localization . . . . .	.6
	Configuring the Display . . . . .	.7
	Configuring for Remote Control . . . . .	.8
	LAN Configuration . . . . .	.8
	GPIB Configuration . . . . .	.9
	Ordering Accessories . . . . .	.9
	Proper Use and Cleaning . . . . .	.10
	Cleaning Suggestions . . . . .	.10
	Returning a Signal Generator to Agilent Technologies . . . . .	.10
	Contacting Agilent . . . . .	.10
<b>3</b>	<b>Operation Verification</b>	
	Running Self Test . . . . .	.12
	Self Test Failure . . . . .	.13
	Frequency Range and Accuracy Check . . . . .	.15
	Frequency Counter Procedure . . . . .	.16
	Spectrum Analyzer Procedure . . . . .	.17
	Troubleshooting Problems with the Frequency Accuracy Check . . . . .	.18
	Checking the Output Power . . . . .	.19
	N5181A Test Procedure . . . . .	.20
	N5182A Test Procedure . . . . .	.21
	Troubleshooting Problems with the Output Power Check . . . . .	.23
<b>4</b>	<b>Regulatory Information</b>	
	Certification . . . . .	.25

---

# Contents

Assistance . . . . . 25

Declaration of Conformity . . . . . 25

Statement of Compliance. . . . . 25

Compliance with Canadian EMC Requirements . . . . . 25

Compliance with Canadian Standards Association Requirements. . . . . 25

Compliance with German Noise Requirements. . . . . 26

# Documentation Overview

- |                             |   |
|-----------------------------|---|
| <b>Installation Guide</b>   | <ul style="list-style-type: none"><li>• Safety Information</li><li>• Receiving the Instrument</li><li>• Environmental &amp; Electrical Requirements</li><li>• Basic Setup</li><li>• Accessories</li><li>• Operation Verification</li><li>• Regulatory Information</li></ul> |
| <b>User's Guide</b>         | <ul style="list-style-type: none"><li>• Instrument Overview</li><li>• Front Panel Operation</li><li>• Security</li><li>• Basic Troubleshooting</li></ul>  |
| <b>Programming Guide</b>    | <ul style="list-style-type: none"><li>• Remote Operation</li><li>• Status Registers</li><li>• Creating &amp; Downloading Files</li></ul>  |
| <b>SCPI Reference</b>       | <ul style="list-style-type: none"><li>• SCPI Basics</li><li>• Command Descriptions</li><li>• Programming Command Compatibility</li></ul>  |
| <b>Service Guide</b>        | <ul style="list-style-type: none"><li>• Troubleshooting</li><li>• Assembly Replacement</li><li>• Replaceable Parts</li><li>• Post-Repair Procedures</li><li>• Safety and Regulatory Information</li></ul>   |
| <b>Key Help<sup>a</sup></b> | <ul style="list-style-type: none"><li>• Key function description</li><li>• Related SCPI commands</li></ul>  |

<sup>a</sup>Press the **Help** hardkey, and then the key for which you wish help.



---

# 1 Safety Information

- [Warnings, Cautions, and Notes](#)
- [General Safety Considerations](#)
- [Instrument Markings](#) on page 2

## Warnings, Cautions, and Notes

The documentation for this product uses the following safety notations. Familiarize yourself with each notation and its meaning before operating the signal generator.

---

**WARNING**    *Warning* denotes a hazard. It calls attention to a condition or situation that could result in personal injury or loss of life. Do not proceed beyond a warning until you fully understand the indicated conditions or situations.

---

---

**CAUTION**    *Caution* calls attention to a condition or situation that could result in damage to or destruction of the signal generator, or in the loss of a user's settings or data. Do not proceed beyond a caution until you fully understand the indicated conditions.

---

---

**NOTE**    *Note* calls the user's attention to an important point or special information in the text.

---

## General Safety Considerations

---

**WARNING**    If the signal generator is not used as specified, the protection provided by the equipment could be impaired. The signal generator must be used in a normal condition only, in which all means for protection are intact.

---

---

**WARNING**    Personal injury may result if the signal generator covers are removed. There are no operator serviceable parts inside. To avoid electrical shock, refer servicing to qualified personnel.

---

## Instrument Markings

The the signal generator has the following markings. Familiarize yourself with each marking and its meaning before operating the signal generator.



The instruction manual symbol. The product is marked with this symbol when it is necessary for you to refer to instructions in the manual.



The CE mark is a registered trademark of the European Community. If this symbol is accompanied by a year, it is the year when the design was proven.



The CSA mark is a registered trademark of the Canadian Standards Association International.



The C-Tick Mark is a trademark registered to the Australian Spectrum Management Agency. This indicates compliance with all Australian EMC regulatory information.



This is the symbol of an Industrial Scientific and Medical Group 1 Class A Product. (CISPER 11, Clause 4)



This symbol marks the on position of the power line switch.



This symbol marks the standby position of the power line switch.



This symbol indicates that the input power required is AC.



This symbol indicates conformance to the LXI Standard Specifications.



This is a marking to indicate product compliance with the Canadian Interference-Causing Equipment Standard (ICES-001)



DO NOT THROW BATTERIES AWAY BUT  
COLLECT AS SMALL CHEMICAL WASTE.

This symbol indicates separate collection for electrical and electronic equipment, mandated under EU law as of August 13, 2005. All electric and electronic equipment are required to be separated from normal waste for disposal (Reference WEEE Directive, 2002/96/EC).



---

## 2 Getting Started

- [Checking the Shipment](#)
- [Signal Generator Physical Characteristics](#)
- [Meeting Environmental and Electrical Requirements](#) on page 4
- [Configuring the Display](#) on page 7
- [Configuring for Remote Control](#) on page 8
- [Ordering Accessories](#) on page 9
- [Proper Use and Cleaning](#) on page 10
- [Returning a Signal Generator to Agilent Technologies](#) on page 10
- [Contacting Agilent](#) on page 10

### Checking the Shipment

1. Inspect the shipping container for damage.  
Signs of damage can include a dented or torn shipping container or cushioning material that indicates signs of unusual stress or compacting.
2. Carefully remove the contents from the shipping container and verify that your order is complete.  
The following items are included with each signal generator:
  - Installation Guide
  - documentation CD-ROM (CD-ROM contents are also available in hardcopy format)
  - three-prong AC power cord specific to geographic location
3. Verify that the options you ordered are included with the shipment by checking the serial number label on the rear of the signal generator and the packing literature included with the shipment.

See also, “[Ordering Accessories](#)” on page 9.

### Signal Generator Physical Characteristics

- Height: 10.16 cm (4 in)
- Width: 42.55 cm (16.75 in)
- Depth: 48.90 cm (19.25 in)
- Weight (N5181A): 10.66 kg (23.5 lb)
- Weight (N5182A): 12.47 kg (27.5 lb)

## Meeting Environmental and Electrical Requirements

### Environment

- indoor use
- altitudes < 15,000 feet (4,572 meters)
- 0 to 55°C temperature, unless otherwise specified
- relative humidity - type tested at 95%, +40°C (non-condensing)

---

**CAUTION** This product is designed for use in INSTALLATION CATEGORY II and POLLUTION DEGREE 2, per IEC 61010 Second Edition and 664, respectively.

---

### Ventilation

Ventilation holes are located on the rear panel and all four sides of the signal generator cover. To ensure proper air flow through the signal generator, do not allow these holes to be obstructed.

### Line Setting Requirements

---

**CAUTION** The signal generator has autoranging line voltage input; ensure that the supply voltage is within the specified range.

---

**Voltage:** 100/120 volts nominal  
220/240 volts nominal

**Frequency:** for 100/120 volts: 50/60 Hz nominal  
for 220/240 volts: 50/60 Hz nominal

**Power:** 250 watts maximum

## Connecting the AC Power Cord

This is a Safety Class 1 Product provided with a protective earth ground incorporated into the power cord. The front panel switch is only a standby switch; it is not a line switch. The AC power cord is the disconnecting device that disconnects the signal generator mains circuits from the mains supply. Alternatively, an external switch or circuit breaker, readily identifiable and easily reached by the operator, may be used as a disconnecting device.

---

**WARNING**    **The mains plug shall be inserted only in a socket outlet provided with a protective earth contact. Always use the three-prong AC power cord supplied with the signal generator. Personal injury can occur if there is any interruption of the protective conductor inside or outside of the signal generator. Intentional interruption is prohibited.**

---

---

**CAUTION**    The mains wiring and connectors shall be compatible with the connector used in the premise electrical system. Inadequate earth grounding can damage the signal generator. Always use the three-prong AC power cord supplied with the signal generator. See [page 6](#) for a list of available power cords.

---









Connect the AC power cord as follows:

1. Ensure that the power cord is not damaged.
2. Install the signal generator so that one of the following items is readily identifiable and easily reached by the operator: AC power cord, alternative switch, or circuit breaker.
3. Insert the mains plug into a socket outlet provided with a protective earth grounding.

## AC Power Cord Localization

The AC power cord included with the signal generator is appropriate for the final shipping destination. You can order additional AC power cords for use in different areas.

The following table lists the available AC power cords, illustrates plug configurations, and identifies the geographic area in which each cord is appropriate.

Plug Type <sup>a</sup>	Cable Part Number	Plug <sup>b</sup> Description	Length cm (in.)	Cable Color	For Use in Country
	8120-1351	Straight BS 1363A	229 (90)	Mint Gray	Option 900 United Kingdom, Hong Kong, Cyprus, Nigeria, Singapore, Zimbabwe
	8120-1703	90°	229 (90)	Mint Gray	
	8120-1369	Straight AS 3112	210 (79)	Gray	Option 901 Argentina, Australia, New Zealand, Mainland China
	8120-0696	90°	200 (78)	Gray	
	8120-1378	Straight NEMA 5-15P	203 (80)	Jade Gray	Option 903 United States, Canada, Brazil, Colombia, Mexico, Philippines, Saudi Arabia, Taiwan
	8120-1521	90°	203 (80)	Jade Gray	
	8120-4753	Straight NEMA 5-15P	229 (90)	Gray	Option 918 Japan
	8120-4754	90°	229 (90)	Gray	
	8120-1689	Straight CEE 7/VII	200 (78)	Mint Gray	Option 902 Continental Europe, Central African Republic, United Arab Republic
	8120-1692	90°	200 (78)	Mint Gray	
	8120-2104	Straight SEV Type 12	200 (78)	Gray	Option 906 Switzerland
	8120-2296	90°	200 (78)	Gray	
	8120-2956	Straight SR 107-2-D	200 (78)	Gray	Option 912 Denmark
	8120-2957	90°	200 (78)	Gray	
	8120-4211	Straight IEC 83-B1	200 (78)	Mint Gray	Option 917 South Africa, India
	8120-4600	90°	200 (78)	Mint Gray	
	8120-5182	Straight SI 32	200 (78)	Jade Gray	Option 919 Israel
	8120-5181	90°	200 (78)	Jade Gray	

a. E = earth ground, L = line, and N = neutral.

b. Plug identifier numbers describe the plug only. The part number is for the complete cable assembly.

plugs

## Configuring the Display

Screen saver settings are persistent states; they are unaffected by preset or a power cycle. Use the arrow keys, numeric keypad, or front panel knob to adjust numeric values.

Figure 2-1 Display Softkeys

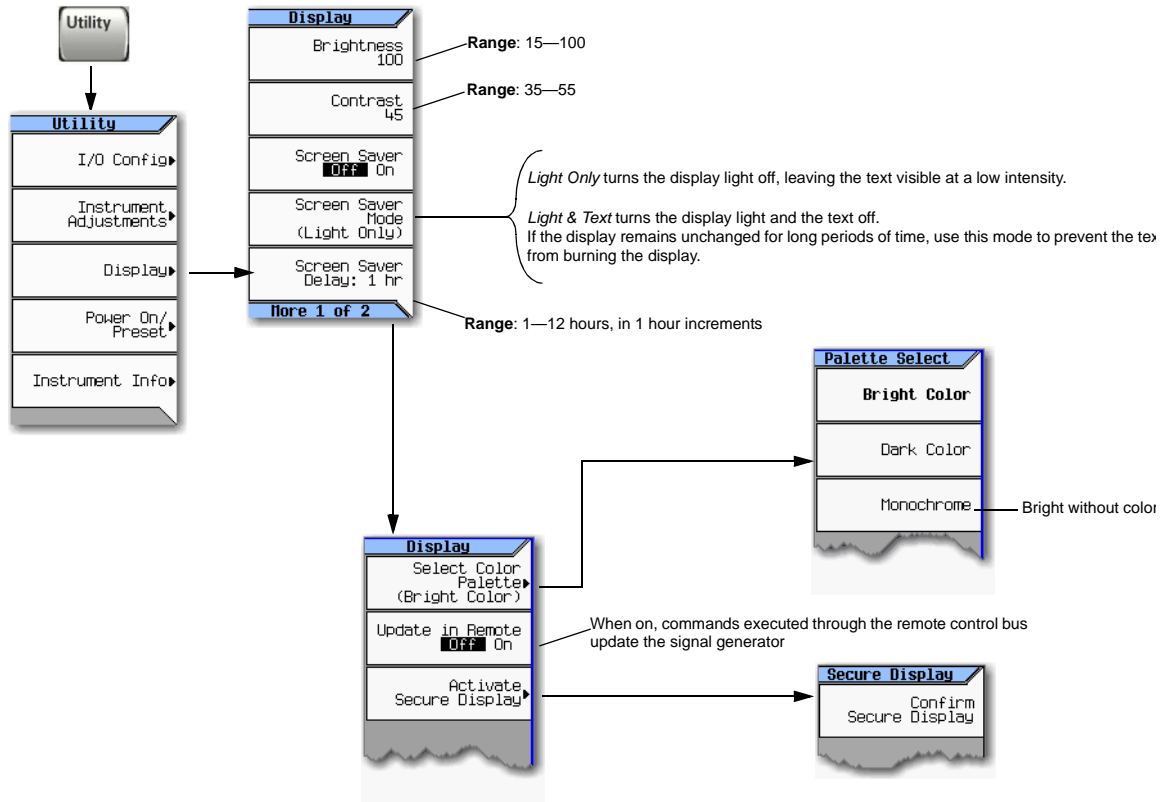

For details on a key, press **Help** and then the desired key.

**NOTE** With both brightness and contrast set to minimum, the display may be too dark to see the softkeys. If this happens, use [Figure 2-1](#) to locate the brightness and contrast softkeys and adjust their values so that you can see the display.

## Configuring for Remote Control

### LAN Configuration

#### Configuring the LAN Interface

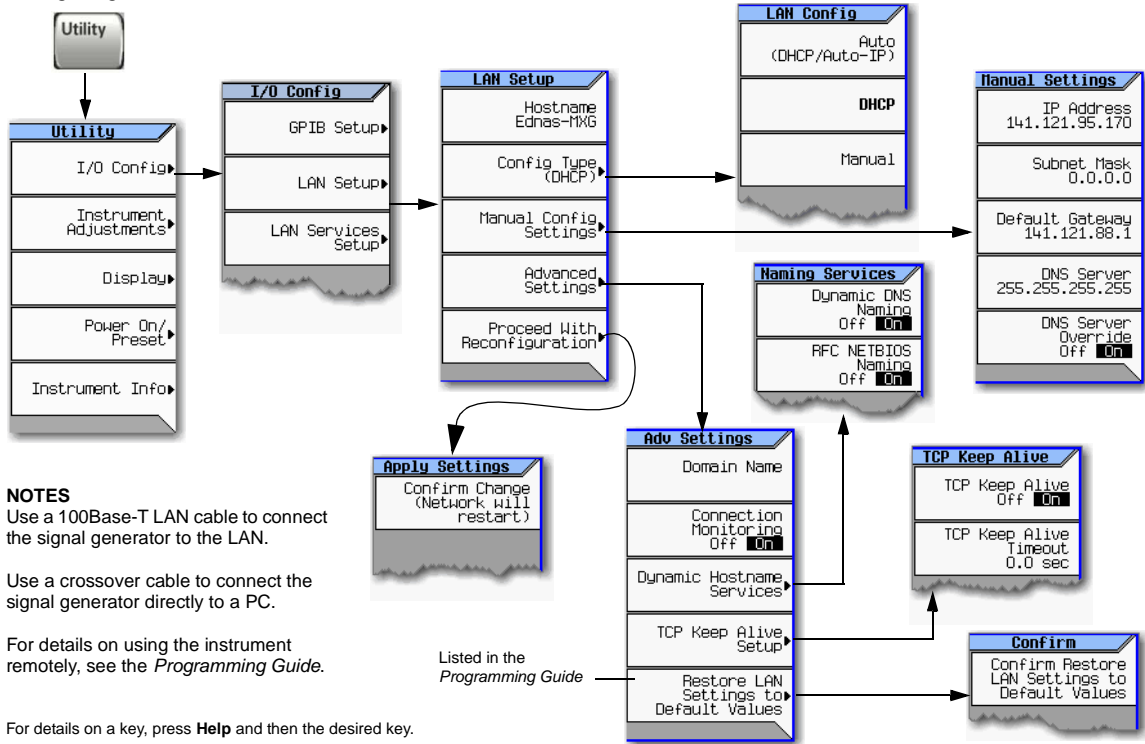

**NOTES**

Use a 100Base-T LAN cable to connect the signal generator to the LAN.

Use a crossover cable to connect the signal generator directly to a PC.

For details on using the instrument remotely, see the *Programming Guide*.

For details on a key, press **Help** and then the desired key.

#### Enabling LAN Services: Browser, Sockets, and VXI-11

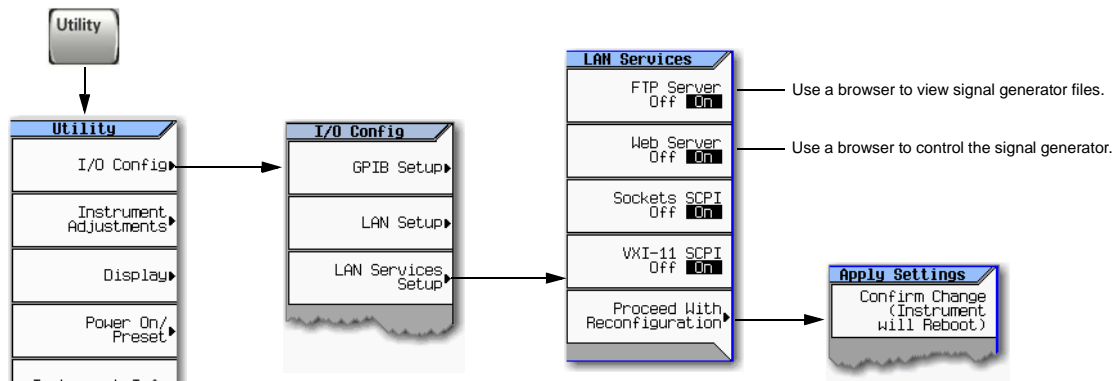

## GPIB Configuration

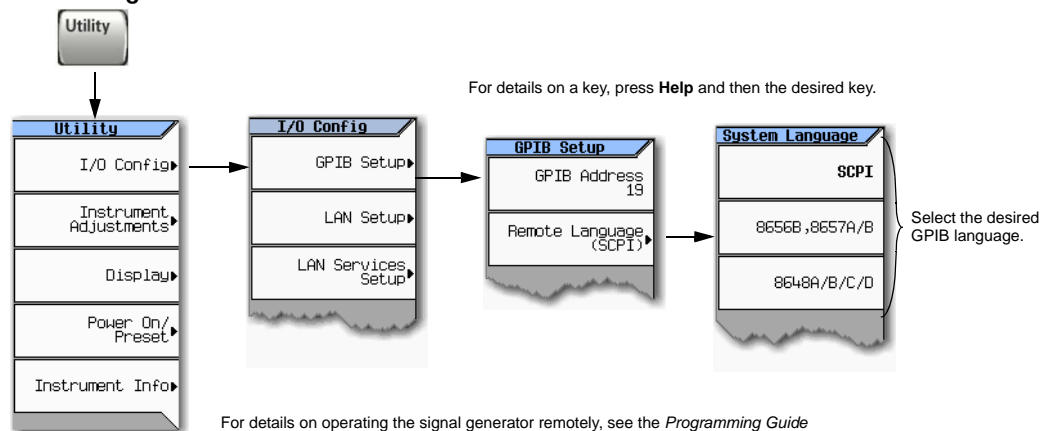

## Ordering Accessories

You can purchase accessories or documentation at: <http://www.agilent.com/find/mxg>

If you do not have access to the Internet, please contact your Agilent field engineer.

See also, “Contacting Agilent” on page 10.

Description <sup>a</sup>	Part Number
Front Handle Kit	5063-9227
Rack Mount Kit with Handles	5063-9221
Data Sheet (N5181A)	5989-5311EN
Data Sheet (N5182A)	5989-5261EN
Installation Guide	N5180-90002
User's Guide	N5180-90003
SCPI Reference	N5180-90004
Programming Guide	N5180-90005
Service Guide	N5180-90006
Document Set:	N5180-90001
<ul style="list-style-type: none"> <li>• Data Sheet</li> <li>• User's Guide</li> <li>• Programming Guide</li> <li>• SCPI Reference</li> </ul>	

Description	Part Number
Documentation CD-ROM: <i>PDF files:</i>	N5180-90007
<ul style="list-style-type: none"> <li>• Documentation Set</li> <li>• Installation Guide</li> <li>• Service Guide</li> </ul>	
<i>Text files:</i>	
<ul style="list-style-type: none"> <li>• error messages</li> <li>• programming examples</li> </ul>	

<sup>a</sup>For a description of the contents of each guide and reference, see [page v](#).

## Proper Use and Cleaning

The signal generator cover protects against physical contact with internal assemblies that contain hazardous voltages, but does not protect internal assemblies against contact with liquids. To avoid damage and personal injury, ensure that liquids are positioned away from the signal generator.

---

**WARNING**    **Personal injury may result if the signal generator is not used as specified. Unspecified use impairs the protection provided by the equipment. The signal generator must be used with all means for protection intact.**

---

## Cleaning Suggestions

---

**WARNING**    **Electrical shock may result if the signal generator is not disconnected from the mains supply before cleaning. Do not attempt to clean internally.**

---

To ensure good connections, regularly clean the instrument's front and rear panel connectors.

To prevent dust build-up that could potentially obstruct ventilation, periodically clean the instrument's cover. Use a dry cloth or a cloth slightly dampened with water to clean the external case parts.

## Returning a Signal Generator to Agilent Technologies

1. Gather as much information as possible about the signal generator's problem.
2. Contact Agilent using the phone number that is specific to your geographic location. These phone numbers are listed on the Internet at <http://www.agilent.com/find/assist>. If you do not have access to the Internet, contact your Agilent field engineer.

After you provide information about the signal generator and its condition, you will receive information about where to ship your signal generator for repair.

3. Ship the signal generator in the original factory packaging materials, if available, or use similar packaging to properly protect the signal generator.

## Contacting Agilent

Assistance with test and measurements needs, information on finding a local Agilent office, and information on purchasing accessories and documentation are available on the Internet at: <http://www.agilent.com/find/assist>

If you do not have access to the Internet, please contact your Agilent field engineer.

---

**NOTE**    In correspondence or telephone conversation, refer to the signal generator by its model number and full serial number. With this information, the Agilent representative can determine if your unit is still within its warranty period.

---



---

## 3 Operation Verification

Operation verification is a series of tests used to confirm that the signal generator is operating properly, or to diagnose problems. Operation verification does not verify performance to instrument specifications.

Perform operation verification when you initially set up the signal generator, after a minor repair (refer to the *Service Guide* for details), or when the integrity of the signal generator is in question.

- [Running Self Test](#) on page 12
- [Frequency Range and Accuracy Check](#) on page 15
- [Checking the Output Power](#) on page 19

## Running Self Test

Self Test is a series of internal tests of signal generator functions. If this test fails, refer to “[Self Test Failure](#)” on page 13 for further instructions.

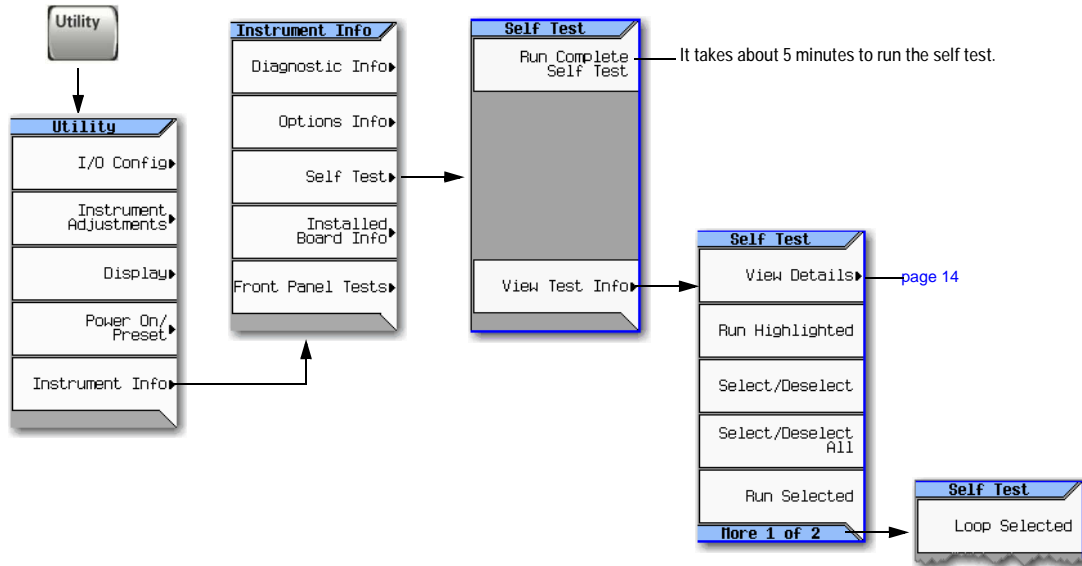

Use the following procedure to run self test:

1. Disconnect all external cables, including GPIB, LAN, and USB cables.
2. Preset the signal generator: Press **Preset** > **Utility** > **Instrument Info** > **Self Test**.

The following message appears:

- The current status of the self-test is: Incomplete. Not all tests have been run.

3. Press **Run Complete Self Test**.

An activity bar displays on the screen indicating the test progress.

If you press **Abort** while self-test is running, the following message displays:

- The current status of the self-test is: Incomplete. Not all tests have been run.

When self-test completes, one of the following messages displays:

- The current status of the self-test is: Passed
- The current status of the self-test is: Failure. One or more tests have failed. System diagnostics indicate this test as the root failure: xxx

If the signal generator fails only one test, the title of the failed test displays. If the signal generator fails more than one test, the test number of the most significant failure displays.

## Self Test Failure

1. Confirm that all external cables, including GPIB, LAN, and USB cables, are disconnected from the signal generator and repeat the self-test.
2. If the self-test continues to fail, the signal generator requires service. If you are unable to service the signal generator, send it to an Agilent service center for repair. Include a detailed description of the failed test(s) and any displayed error messages.

See [“Viewing Test Results” on page 14](#) for information about viewing detailed self test results.

See [“Returning a Signal Generator to Agilent Technologies” on page 16](#) for return instructions.

### Viewing Test Results

Utility > Instrument Info >  
Self Test >

If Self Test fails, the summary indicates the probable cause.

**Self Test**

Run Complete Self Test

**FREQUENCY** 6.000 000 000 00 GHz **AMPLITUDE** -144.00 dBm

**Self Test Summary**

The current status of self test is: Failure  
One or more tests have failed. System diagnostics indicate this test as the root failure: 706

Passes: 58 Fails: 1

Use the arrow keys to highlight the desired test and press View Details.

**FREQUENCY** 6.000 000 000 00 GHz **AMPLITUDE** -144.00 dBm **Self Test**

View Details

Run Highlighted

Select/Deselect

Select/Deselect All

Run Selected

**Test Editor**

Sel	ID#	Test Name	Status
x	701	BB Board Voltages	PASSED
x	702	Interface FPGA Checks	PASSED
x	704	BB 500 MHz Clk	PASSED
x	705	ARB FPGA Checks	PASSED
x	706	Memory Test	FAILED
x	707	User Clock Test	PASSED
x	708	Data Path CRC Test	PASSED
----- BB Analog Baseband Self Tests -----			
x	801	Internal IQ Offset	PASSED
x	802	I & Q Dacs	PASSED

\*\*\* DEMO CODE \*\*\* 06/15/2006 13:51 **Page 1 of 2**

**FREQUENCY** 6.000 000 000 00 GHz **AMPLITUDE** -144.00 dBm

**Test View**

Test Name	Value	Lower	Upper	Fail
Sequencer RAM	0	1	1	**
Dyn Seq RAM	1	1	1	
I&Q data RAM	1	1	1	
Marker data RAM	1	1	1	

\*\*\* DEMO CODE \*\*\* 06/15/2006 13:43

## Frequency Range and Accuracy Check

The frequency range is tested by determining the frequency accuracy relative to the timebase at the frequency limits of the signal generator. This test can be performed with either a frequency counter or a spectrum analyzer.

**Table 3-1 Recommended Equipment for Checking N5181A/82A Frequency Range and Accuracy**

Test Equipment	Recommended Model
Frequency Counter	Agilent 53131A or 53132A frequency counter with option 010 and 050 or 124
Spectrum Analyzer	Agilent E4440A PSA Series spectrum analyzer

## Frequency Counter Procedure

1. Connect the equipment as shown.

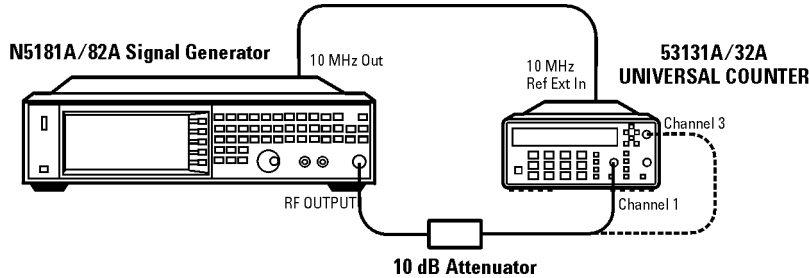

2. Preset the signal generator: Press **Preset**.
3. Turn modulation off: Press the **Mod On/Off** so that the MOD On/Off LED turns off.
4. Set the amplitude: Press **Amplitude** and enter 0 dBm.
5. Turn RF on: Press **RF On/Off** so that the RF On/Off LED lights.
6. Verify that the frequency counter is locked to the 10 MHz external reference frequency ( $\pm 1$  Hz).
7. For maximum accuracy, set the gate time on the frequency counter to  $> 5$  seconds. (Press **Gate & ExtArm** twice and use the arrow keys to set the value.)
8. Set the frequency: Press **Frequency** and set the signal generator to the first frequency listed in [Table 3-2](#).
9. Confirm that the measured frequency is within the limits listed.
10. Repeat step 8 and step 9 for all of the frequencies in the table that are within the frequency range of your signal generator.

Table 3-2 Frequency Accuracy Limits

Frequency (MHz)	Limit (Hz)
0.25 MHz	$\pm 1$
0.5 MHz	$\pm 1$
1 MHz	$\pm 1$
10 MHz	$\pm 1$
50 MHz	$\pm 1$
100 MHz	$\pm 1$
500 MHz	$\pm 1$
800 MHz	$\pm 1$
1000 MHz	$\pm 1$
2000 MHz	$\pm 1$
3100 MHz	$\pm 1$
4000 MHz	$\pm 1$
5000 MHz	$\pm 1$
6000 MHz	$\pm 1$

**NOTE** For frequencies  $< 200$  MHz, use Channel 3 on the frequency counter (press **Freq Ratio** until CH3: displays).

## Spectrum Analyzer Procedure

1. Connect the equipment as shown.

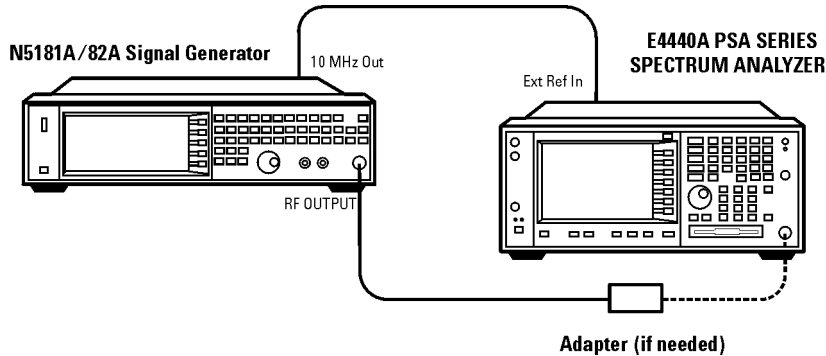

2. Verify that the spectrum analyzer is locked to the 10 MHz external reference frequency.
3. Align the spectrum analyzer: Press **System > Alignment > Align All Now**.
4. Preset the signal generator: Press **Preset**.
5. Turn modulation off: Press the **Mod On/Off** so that the MOD On/Off LED turns off.
6. Set the amplitude: Press **Amplitude** and enter 0 dBm.
7. Turn RF on: Press **RF On/Off** so that the RF On/Off LED lights.
8. Set the frequency: Press **Frequency** and set the signal generator to the first frequency listed in [Table 3-3](#).
9. Confirm that the measured frequency is within the limits listed in the table.
10. Repeat step 8 and step 9 for all of the frequencies in the table that are within the frequency range of your signal generator.

Table 3-3 Frequency Accuracy Limits

Frequency (MHz)	Limit (Hz)
0.25 MHz	±1
0.5 MHz	±1
1 MHz	±1
10 MHz	±1
50 MHz	±1
100 MHz	±1
500 MHz	±1
800 MHz	±1
1000 MHz	±1
2000 MHz	±1
3100 MHz	±1
4000 MHz	±1
5000 MHz	±1
6000 MHz	±1

## Troubleshooting Problems with the Frequency Accuracy Check

- Verify the cables are connected correctly.
- If you are using a frequency counter, verify that you are using the correct channel for the frequencies you are measuring.
- If you are using a spectrum analyzer, verify that the spectrum analyzer is set to external reference.



## Checking the Output Power

This test verifies that the CW output power from the signal generator is within defined limits. The following table lists the preferred equipment for this test.

Test Equipment	Recommended Model
Power Meter	Agilent E4418B or E4419A/B E-Series power meter
Power Sensor, Input: Type-N (m)	Agilent E9304A H19 power sensor

- [N5181A Test Procedure](#) on page 20
- [N5182A Test Procedure](#) on page 21

If this test fails, refer to “[Troubleshooting Problems with the Output Power Check](#)” on page 23 for further instructions.

## N5181A Test Procedure

1. Zero and calibrate the power sensor to the power meter:

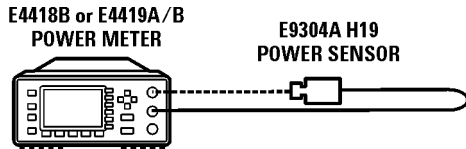

2. Connect the equipment as shown:

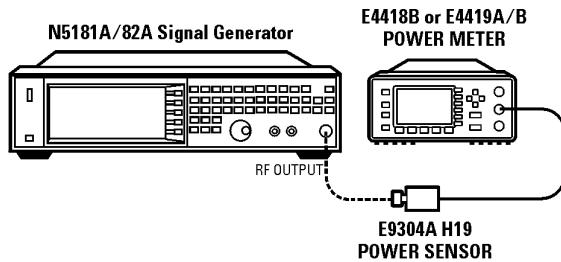

3. Preset the signal generator: Press Preset.
4. Turn RF on: Press RF On/Off so that the RF On/Off LED lights.
5. Turn modulation off: Press Mod On/Off so that the Mod On/Off LED turns off.
6. Set the frequency: Press Frequency and enter the first frequency value listed in [Table 3-4](#).
7. Set the amplitude: Press Amplitude and enter the amplitude value for that frequency.
8. Configure the power meter for the measurement.
  - a. Press the Frequency Cal Fac button on the power meter.
  - b. Select a power meter channel (if applicable).
  - c. Use the arrow keys to enter the frequency at which to measure the power.
9. Measure the output power level.
10. Repeat steps 6 through 9 to measure power at each of the 15 frequencies listed in [Table 3-4](#).

11. Confirm that the measured power levels are within the limits listed in the table.

**NOTE** Limit values are due to power meter uncertainty.

Table 3-4 Leveled Output Power Limits

N5181A Output Power		
Frequency	Amplitude (dBm)	Limits (dB)
125 MHz	7	±1
275 MHz	7	±1
338 MHz	7	±1
425 MHz	7	±1
538 MHz	7	±1
675 MHz	7	±1
850 MHz	7	±1
1075 MHz	7	±1
1350 MHz	7	±1
1700 MHz	7	±1
2150 MHz	7	±1
2700 MHz	7	±1
3400 MHz	7	±1
4300 MHz	7	±1
5400 MHz	7	±1

## N5182A Test Procedure

### Test Setup

1. Zero and calibrate the power sensor to the power meter:

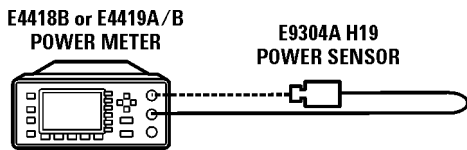

2. Connect the equipment as shown below:

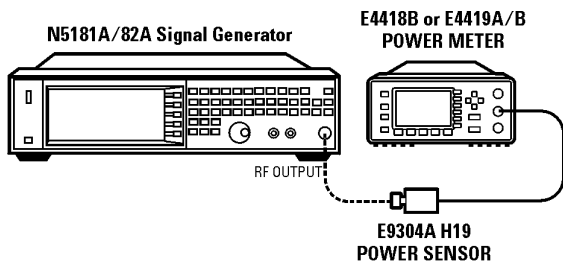

3. Preset the signal generator: Press Preset.
4. Turn RF on: Press RF On/Off so that the RF On/Off LED lights.
5. Turn modulation off:  
Press Mod On/Off so that the Mod On/Off LED turns off.

### Without Modulation

6. Set the signal generator frequency to the first value listed in [Table 3-6](#):  
Press **Frequency** > 125 > MHz.
7. Set the amplitude to 7 dBm:  
Press **Amplitude** > 7 > dBm.
8. Configure the power meter as follows:
  - a. On the power meter, press the **Frequency Cal Fac** button.
  - b. If applicable, select a power meter channel.

- c. Use the arrow keys to enter the frequency at which to measure the power.

9. Measure the output power level.
10. Repeat steps 6 through 9 for the remaining frequencies in the table, and confirm that the power level at each point is within limits.

Table 3-5

N5182A Output Power without Modulation		
Frequency (MHz)	Amplitude (dBm)	Limits (dB)
250	7	±1
338	7	±1
425	7	±1
538	7	±1
675	7	±1
850	7	±1
1075	7	±1
1350	7	±1
1700	7	±1
2150	7	±1
2700	7	±1
3400	7	±1
4300	7	±1
5400	7	±1

### With Modulation

11. Preset the signal generator: Press Preset.
12. Select the factory-supplied waveform SINE\_TEST\_WFM:
  - a. Press **Mode** > Dual ARB > **Select Waveform**.
  - b. Highlight the SINE\_TEST\_WFM waveform.
  - c. Press **Select Waveform**.

13. Turn the arbitrary waveform player on: Press the **ARB** softkey to highlight **On**.
14. Set the frequency to the first value listed in [Table 3-6](#):  
Press **Frequency > 125 > MHz**.
15. Set the amplitude to 7 dBm:  
Press **Amplitude > 7 > dBm**.
16. Configure the power meter as follows:
  - a. On the power meter, press the **Frequency Cal Fac** button.
  - b. Select a power meter channel (if applicable).
  - c. Use the arrow keys to enter the frequency at which to measure the power.
17. Measure the output power.
18. Repeat steps [14](#) through [17](#) for the remaining frequencies listed in [Table 3-6](#), and confirm that the power level at each point is within limits.

Table 3-6

N5182A Output Power with Modulation		
Frequency (MHz)	Amplitude (dBm)	Limits (dB)
250	7	±1
323	7	±1
512	7	±1
814	7	±1
1275	7	±1
2025	7	±1
2750	7	±1
3750	7	±1
5250	7	±1

### Troubleshooting Problems with the Output Power Check

- Verify that you are using the appropriate power sensor.
- Normally, power sensor calibration factors are automatically downloaded to the power meter when the power meter turns on. If this does not occur, manually enter the correct calibration factors for the power sensor you are using.
- Verify that the power sensor is properly calibrated to the power meter.



---

## 4 Regulatory Information

### Certification

Agilent Technologies certifies that this product met its published specifications at the time of shipment from the factory. Agilent Technologies further certifies that its calibration measurements are traceable to the United States National Institute of Standards and Technology, to the extent allowed by the Institute's calibration facility, and to the calibration facilities of other International Standards Organization members.

### Assistance

Product maintenance agreements and other customer assistance agreements are available for Agilent Technologies products. For assistance, contact Agilent Technologies (see [page 10](#)).

### Declaration of Conformity

A copy of the Manufacturer's EU Declaration of Conformity for this instrument can be obtained by contacting your local Agilent Technologies sales representative (see "[Contacting Agilent](#)" on [page 10](#)).

### Statement of Compliance

This product has been designed and tested in accordance with IEC Publication 61010, *Safety Requirements for Electronic Measuring Apparatus*, and has been supplied in a safe condition. The documentation contains information and warnings which must be followed by the user to ensure safe operation and to maintain the product in a safe condition.

### Compliance with Canadian EMC Requirements

This ISM device complies with Canadian ICES-001.

Cet appareil ISM est conforme a la norme NMB du Canada.

### Compliance with Canadian Standards Association Requirements

This product complies with CSA 1010 Edition 2.

## Compliance with German Noise Requirements

This is to declare that this instrument is in conformance with the German Regulation on Noise Declaration for Machines (Laermangabe nach der Maschinenlaermverordnung -3.GSGV Deutschland).

Acoustic Noise Emission/Geraeuschemission	
LpA < 70 dB	LpA < 70 dB
Operator position	am Arbeitsplatz
Normal position	normaler Betrieb
per ISO 7779	nach DIN 45635 t.19



**A**

## AC

- power cord localization, 6
- power cord, connecting, 5
- symbol, 2

accessories, 9

address, GPIB, 9

Agilent, contacting, 10

altitude requirements, 4

Australian Communications Authority (C-tick) mark, 2

auto-IP, 8

**B**

brightness adjustment, 7

**C**

Canadian

- EMC requirements, 25

- Standards Association, 25

- Standards Association (CSA) mark, 2

cautions, 1

certification, 25

checking the shipment, 3

cleaning suggestions, 10

contrast adjustment, 7

CSA compliance, 25

**D**

Declaration of Conformity, 25

DHCP, 8

dimensions, signal generator, 3

display adjustment, 7

documentation, list of, v

documentation, ordering, 9

**E**

European Community (CE) trademark, 2

**F**

frequency accuracy check, 15

frequency range and accuracy check, 15

FTP server, 8

**G**

German noise requirements, 26

GPIB address, setting, 9

**H**

hostname, setting, 8

humidity requirements, 4

**I**

ICES symbol, 2

ICES-001, 25

IEC Publication 61010, 25

inspection, shipping container, 3

interface, GPIB, 9

interface, LAN, 8

IP address, setting, 8

ISM1-A symbol, 2

**L**

LAN configuration, 8

line setting requirements, 4

LXI standard specifications symbol, 2

**M**

manuals, ordering, 9

**N**

noise requirements, 26

**O**

operation verification, 11

operation, remote, 8

output power, checking, 19

**P**

power

- checking, 19

- connecting, 5

- disconnecting, 5

- line cord, 5, 6

- requirements, 4

- symbol, 2

programming, 8

**R**

regulatory information, 25

remote operation, 8

requirements, 4, 26

returning a signal generator, 10

**S**

safety information, 1

SCPI, enabling, 8

self test, 12

server, enabling, 8

service, Agilent sales and service offices, 10

shipping container, inspection, 3

shipping requirements, 10

sockets, enabling, 8

---

# Index

standby symbol, [2](#)

## T

temperature requirements, [4](#)

troubleshooting output power, [19](#)

## V

ventilation requirements, [4](#)

verification, operation, [11](#)

voltage requirements, [4](#)

VXI-11, enabling, [8](#)

## W

warnings, [1](#)

web server, [8](#)

weight, signal generator, [3](#)